

TECHNICAL DATA SHEET



Model : P2224-10-200/400-ST/OS

Servo Press Module		
Compressive Force	KN	10
Tensile Force	KN	10
Stroke	mm	200/400
Max Ram Speed	mm/sec	200
Max Ram Acceleration	mm/sec ²	1.3
Dwell Time at Nominal	sec	4
Resolution	mm	0.01
Ram Repeatability ±	mm	0.01
Weight	Kg	53
Admissible Tool Weight	Kg	10
Operating Temperature	C°	50°
Protection Class	IP	54
Servo Motor		
Servo Motor Rating	KW	1
Holding Brake	√ (Option)	
Encoder	Absolute Multiturn	
Std Cable length	Mtr	5

Servo Drive Powe Unit		
Minimum Input Voltage 3Ø	Vac	200
Maximum Input Voltage 3Ø	Vac	500
Nominal Output Current	A	4.5
Peak Output Current	A	11.5
Max output power	KW	1

Force Sensor		
Force Sensor Capacity	KN	10
Bridge sensitivity	mV/V	2
Measure Accuracy ±	%FS	0.3
Linearity	%/°C	0.1
Cable	Mtr	5
Maximum operating safe	%	150
Force Sensor Amplifier		
Power supply	VDC	24
Bridge excitation	VDC	10
Bridge sensitivity	mV/V	
Gain adjustment (Pot - fine	%	50
Linearity	%/°C	0.1
Servo Drive Communication		
Profinet	√	
Modbus TCP	√	
DI/DO	Optional	
Ethernet IP	√	

HMI		
Size	Inch	7 or 10
Recipe storage	No	9999
Pendrive for result storage	√	
Press Programming	√	
Load x Position graph	√	
Limit windows	√	
Press Status monitoring	√	

Dimensions:

P2224-010-200-ST

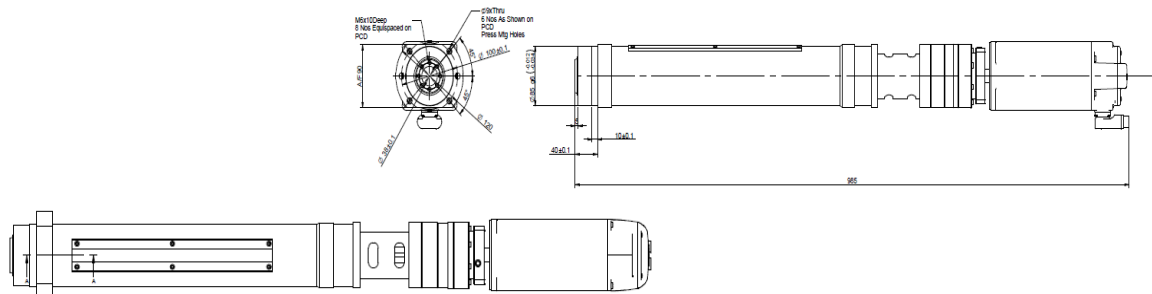

Focus Controls Pvt. Ltd. Gat No 69, At Post- Shindewadi, Tal- Bhor, Pune 412205 India.

P2224-010-200-OS

P2224-010-400-ST

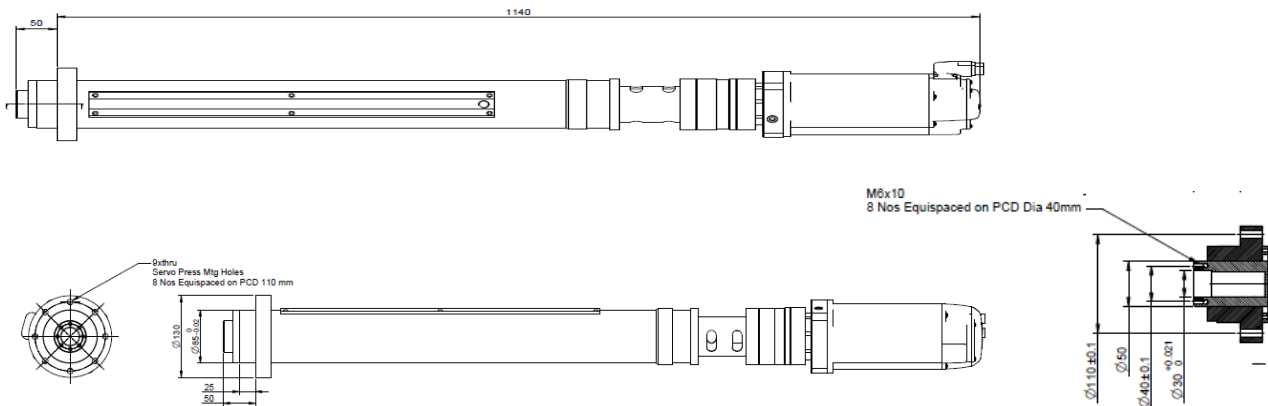

P2224-010-400-OS

